

# Technical Data CAST STEEL • Gate Valves • Flexible Taper Wedge Design

(Class 600-776U, 900-773U, 1500-777U, 2500-787U)

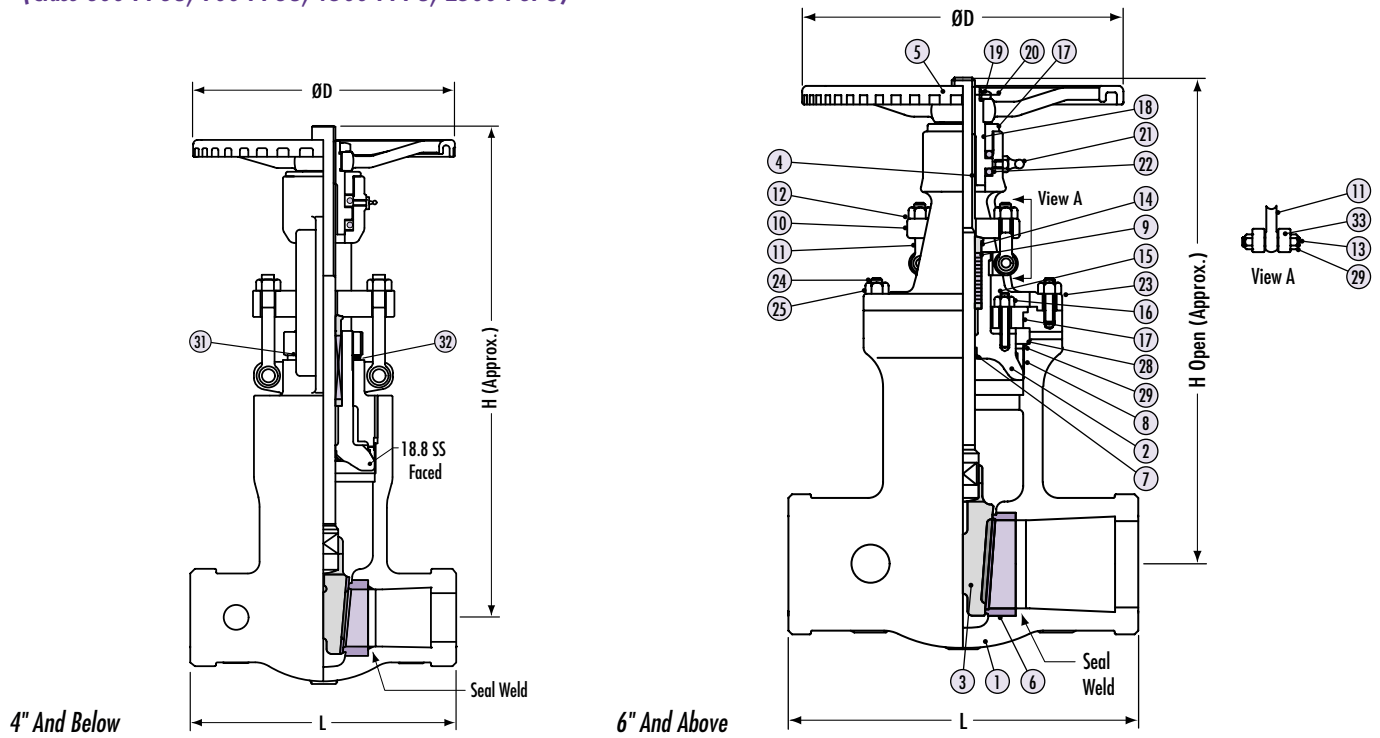

## Dimensional Data (in.), Weights (lbs.) and Flow Coefficients (Cv)

Class 600	2	2 1/2	3	4	6	8	10	12	14	16	18	20	24
Wt. (lbs)	100	140	150	250	460	695	1166	1710	2668	3527	4178	5194	9400
L	7.00	8.50	10.00	12.00	18.00	23.00	28.00	32.00	35.00	39.00	43.00	47.00	55.00
D	7.87	9.84	9.84	13.98	17.72	19.69	24.80	27.95	31.50	35.43	35.43	43.00	43.00
H	19.96	20.87	23.15	27.95	35.67	45.71	53.11	60.31	66.02	78.74	85.94	102.28	112.95
Cv	307	492	709	1297	3107	6634	8493	12801	15357	20172	26273	32141	45707

### Class 900

Wt. (lbs)	121	183	209	287	617	1014	1808	2535	3307	4630	6020	8125	11973
L	8.50	10.00	12.00	14.00	20.00	26.00	31.00	36.00	39.00	43.00	48.00	52.00	61.00
D	12.40	13.98	13.98	13.98	19.69	24.80	27.95	31.50	35.43	35.43	43.00	43.00	51.02
H	23.07	25.98	24.72	29.13	38.07	46.38	56.89	65.28	69.68	72.44	91.26	101.46	107.00
Cv	268	399	649	1214	2854	5026	7844	11465	13913	18172	23938	29554	42557

### Class 1500

Wt. (lbs)	108	165	247	265	816	1345	2866	4409	6393	7694	10209	12613	18169
L	8.50	10.00	12.00	16.00	22.00	28.00	34.00	39.00	42.00	47.00	53.00	58.00	68.00
D	12.40	13.98	13.98	15.75	24.80	27.98	31.50	35.43	43.00	43.00	43.00	51.02	51.02
H	23.07	25.78	28.03	33.70	41.77	44.82	62.44	69.21	69.92	74.88	88.46	103.30	115.00
Cv	268	399	596	1062	2489	4378	6840	9970	11966	15669	20627	25880	37148

### Class 2500

Wt. (lbs)	120	185	298	474	1210	2180	3520	5060	6885	8505	11000	—	—
L	11.00	13.00	14.50	18.00	24.00	30.00	36.00	41.00	44.00	49.00	55.00	62.00	66.00
D	13.98	13.98	13.98	17.72	24.80	27.95	27.95	31.50	35.43	43.00	51.02	51.02	59.00
H	26.53	25.59	27.26	31.69	39.56	52.79	61.18	66.49	71.73	90.47	98.31	107.00	114.00
Cv	173	278	399	668	1648	2954	4696	6889	8368	10955	14481	17587	25483

# Technical Data CAST STEEL • Gate Valves • Parallel Slide Design

(Class 600-S-776U, 900-S-773U, 1500-S-777U, 2500-S-787U)

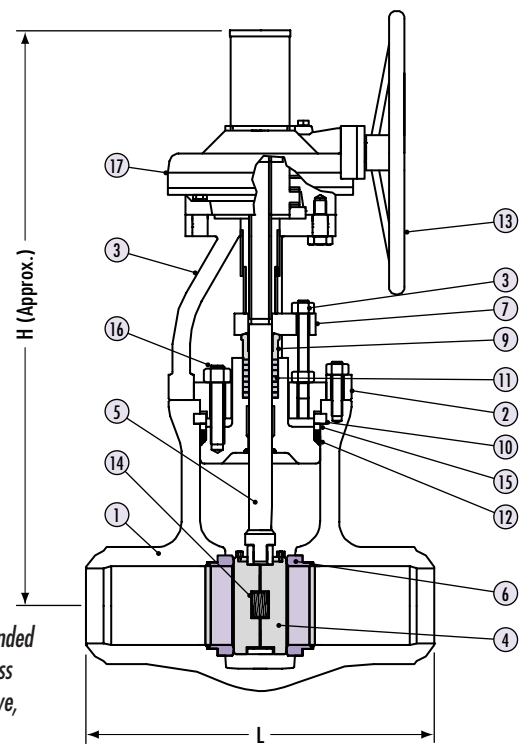
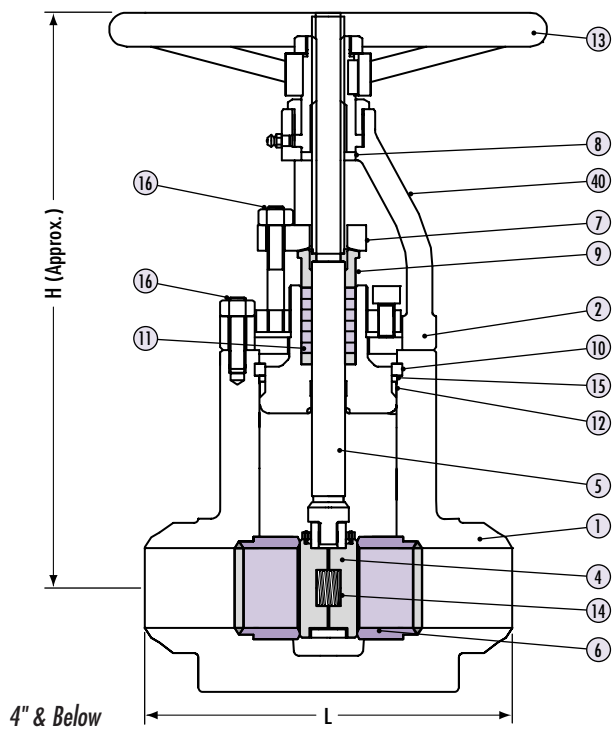

*Gear Operator recommended for sizes 6" & above, Class 900 and sizes 4" & above, Class 1500 & 2500.*

## Dimensional Data (in.) & Weights (lbs.)

Class 600	3	4	6	8	10	12	14	16	18
Wt. (lbs) (approx. cast)	212	331	639	1102	1720	2690	3483	4520	5401
BW (end-to-end)	10.00	12.00	18.00	23.00	28.00	32.00	35.00	39.00	43.00
H (center to top open position, approx.)	25.79	30.71	41.34	52.75	59.84	67.32	70.87	78.94	81.89

Class 900	3	4	6	8	10	12	14	16	18
Wt. (lbs) (approx. cast)	176	276	529	915	1444	2238	2899	3670	4475
BW (end-to-end)	12.00	14.00	20.00	26.00	31.00	36.00	39.00	43.00	45.00
H (center to top open position, approx.)	25.79	30.71	41.34	52.75	59.84	67.32	70.87	78.94	81.89

Class 1500	3	4	6	8	10	12	14	16	18
Wt. (lbs) (approx. cast)	176	298	705	1312	2183	3164	3935	5104	6570
BW (end-to-end)	12.00	16.00	22.00	28.00	34.00	39.00	42.00	47.00	53.00
H (center to top open position, approx.)	25.79	30.91	45.47	54.33	61.42	69.29	70.87	75.60	88.58

Class 2500	3	4	6	8	10	12	14	16	18
Wt. (lbs) (approx. cast)	243	851	827	1653	2701	3538	4255	6063	8554
BW (end-to-end)	14.50	18.00	24.00	30.00	36.00	41.00	44.00	49.00	55.00
H (center to top open position, approx.)	28.35	34.06	44.88	50.59	61.22	64.57	68.90	81.89	84.65