

Technical Data CAST STEEL • Check Valves • Swing Check Design

(Class 600-7165U, 900-7177U, 1500-7189U, 2500-7199U)

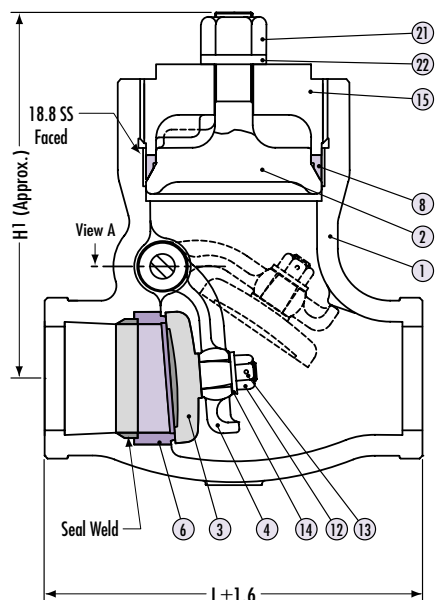

4" & Below

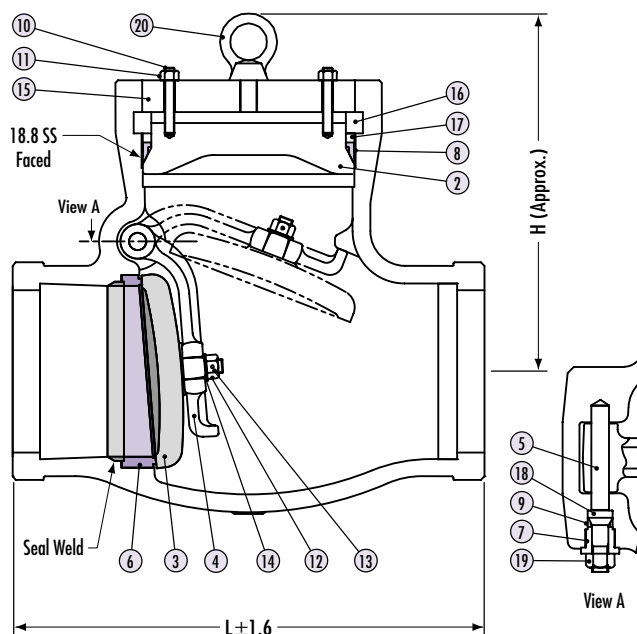

6" & Above

Dimensional Data (in.), Weights (lbs.) and Flow Coefficients (Cv)

Class 600	2	3	4	6	8	10	12	14	16	18	20	24
Wt. (lbs)	80	100	125	287	573	815	1081	1455	1874	2425	3285	4498
L	7.00	10.00	12.00	18.00	23.00	28.00	32.00	35.00	39.00	43.00	47.00	55.00
H	7.52	9.76	12.13	14.37	16.14	18.31	20.08	22.09	24.33	26.50	38.74	30.91
Cv	123	284	519	1243	2213	3397	5120	8384	8344	10508	13745	18751

Class 900

Wt. (lbs)	90	198	243	540	937	1521	2249	2690	2976	4079	5292	6395
L	8.50	12.00	14.00	20.00	26.00	31.00	36.00	39.00	43.00	48.00	52.00	61.00
H	9.57	9.53	14.57	15.75	21.06	21.06	24.02	26.97	29.69	32.64	35.35	38.31
Cv	107	260	486	1142	2010	3138	4586	5565	7269	9575	11821	17023

Class 1500

Wt. (lbs)	90	154	254	551	1036	1632	2425	3110	3528	4630	5733	7718
L	8.50	12.00	16.00	22.00	28.00	34.00	39.00	42.00	47.00	60.50	65.50	76.50
H	9.57	11.81	14.29	15.91	16.10	22.64	26.85	29.61	31.57	34.53	36.89	40.63
Cv	107	238	425	996	1751	2736	3988	4794	6268	8251	10344	14859

Class 2500

Wt. (lbs)	110	187	364	1015	1985	2866	3969	5402	7056	8930	—	—
L	11.00	14.50	18.00	24.00	30.00	36.00	41.00	44.00	48.00	53.00	57.00	66.00
H	10.24	13.78	15.94	17.91	22.44	24.88	32.09	30.55	33.70	36.14	38.82	43.22
Cv	69	160	267	660	1182	1878	2756	3347	4382	5793	7035	10193

Technical Data CAST STEEL • Check Valves • Tilt Disc Design

(Class 600-T-7165, 900-T-7177, 1500-T-7189, 2500-T-7199)

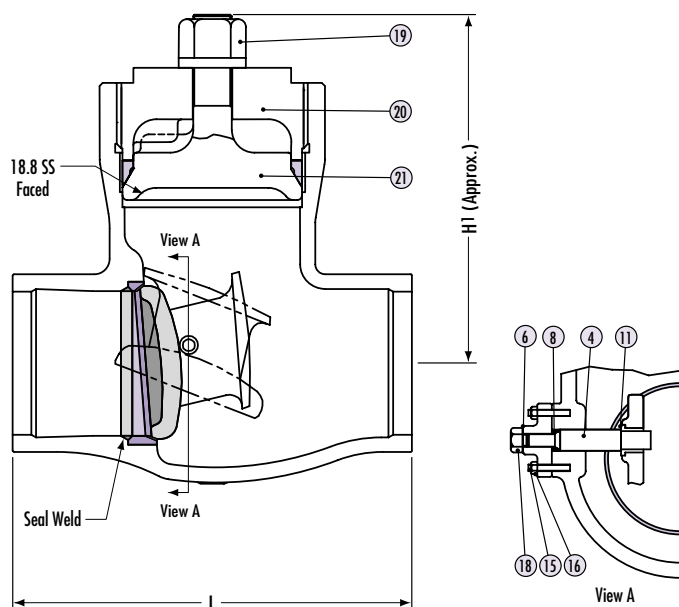

4" & Below

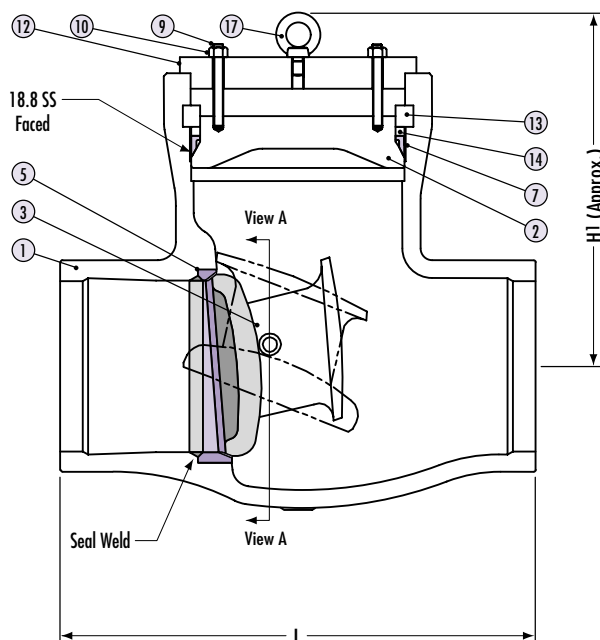

6" & Above

Dimensional Data (in.) and Weights (lbs.)

Class 600	2	2 1/2	3	4	6	8	10	12	14	16	18	20	24
Wt. (lbs)	75	90	110	223	364	686	1124	1477	1808	2469	3131	3990	6521
L	7.00	8.50	10.00	12.00	18.00	23.00	28.00	32.00	35.00	39.00	43.00	47.00	55.00
H	7.52	7.87	8.27	9.41	10.59	12.05	13.62	16.10	17.72	20.08	21.73	23.22	25.39

Class 900

Wt. (lbs)	126	150	172	243	400	925	1367	1962	2400	2675	3800	4900	6000
L	8.50	10.00	12.00	14.00	20.00	26.00	31.00	36.00	39.00	43.00	48.00	52.00	61.00
H	5.60	8.02	9.02	9.84	11.65	13.07	15.12	18.11	19.49	21.81	22.83	24.41	27.36

Class 1500

Wt. (lbs)	132	185	212	362	600	1030	1632	2425	3110	3528	4630	5733	7718
L	8.50	10.00	12.00	16.00	22.00	28.00	34.00	39.00	42.00	47.00	60.50	65.50	76.50
H	7.60	8.07	9.02	9.84	10.24	11.73	15.91	19.06	20.16	22.20	23.31	24.41	28.82

Class 2500

Wt. (lbs)	110	187	364	1015	1985	2866	3969	5402	7056	8930	—		
L	11.00	13.00	14.50	18.00	24.00	30.00	36.00	41.00	44.00	48.00	53.00		
H	7.28	7.87	9.41	9.88	11.81	14.57	16.61	21.26	22.83	20.47	24.80		

Our Quality Commitment...

Zy-Tech Global Industries, Inc. is dedicated to continually improving their state-of-the-art engineering and manufacturing capabilities to improve the overall quality of their products and customer service. Zy-Tech's entire global network of flow control experts consist of highly trained technicians, engineers, and superior testing laboratories to ensure that all products supplied to our customers are 100%

in accordance with industry standards as well as our own Quality Management System.



ZY-TECH GLOBAL INDUSTRIES

Note: This catalog is for reference only. All information is subject to change without notice.