

Zy-Gear BG107 Bevel Gear Operator

Parts And Materials

Item	Part Name	Material
1	Hex Bolt	Carbon Steel
2	Washer	Carbon Steel
3	Handwheel	Carbon Steel
4	Key	Carbon Steel
5	Snap Ring	Spring Steel
6	Input Shaft	AISI 1045
7	Hex Nut	Carbon Steel
8	O-Ring	Nitrile
9	Cap	Carbon Steel
10	Gasket	Rubber
11	Ball Bearing	Commercial
12	Set Screw	Carbon Steel
13	Pinion	AISI 4135
14	Grease Fitting	Brass
15	Housing	Cast Iron
16	O-Ring	Nitrile
17	Drive Sleeve	Ductile Iron
18	Cap Screw	Carbon Steel
19	Bevel Gear	AISI 4135
20	Balls	Hardened Steel
21	O-Ring	Nitrile
22	Cap Screw	Carbon Steel
23	Snap Ring	Spring Steel
24	Base	Carbon Steel
25	Key	Carbon Steel
26	O-Ring	Nitrile

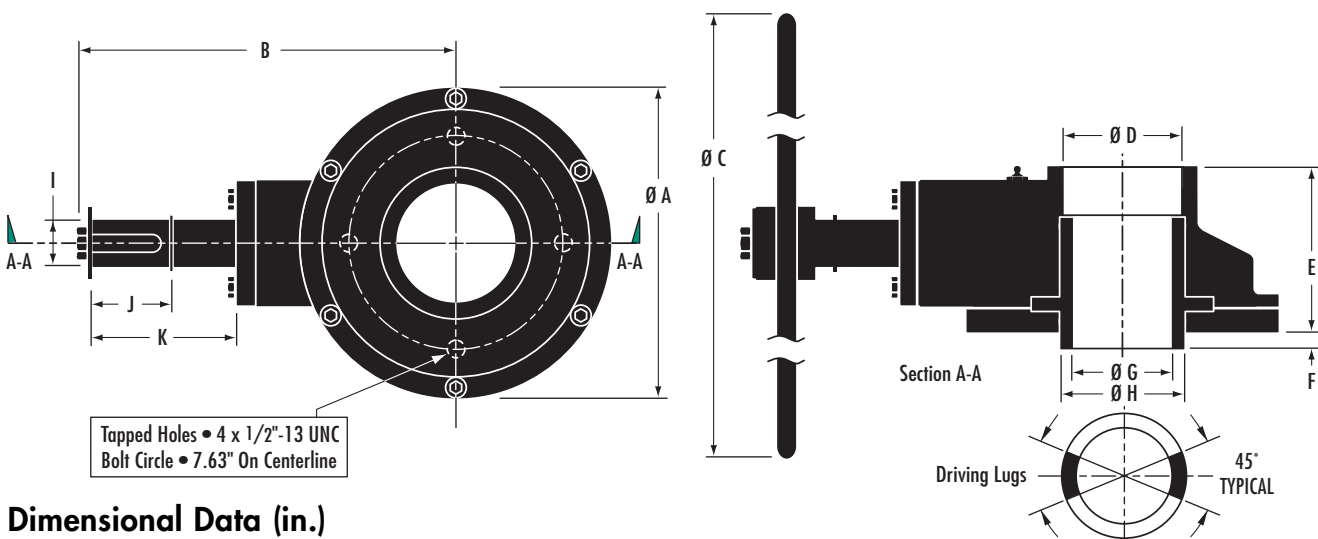
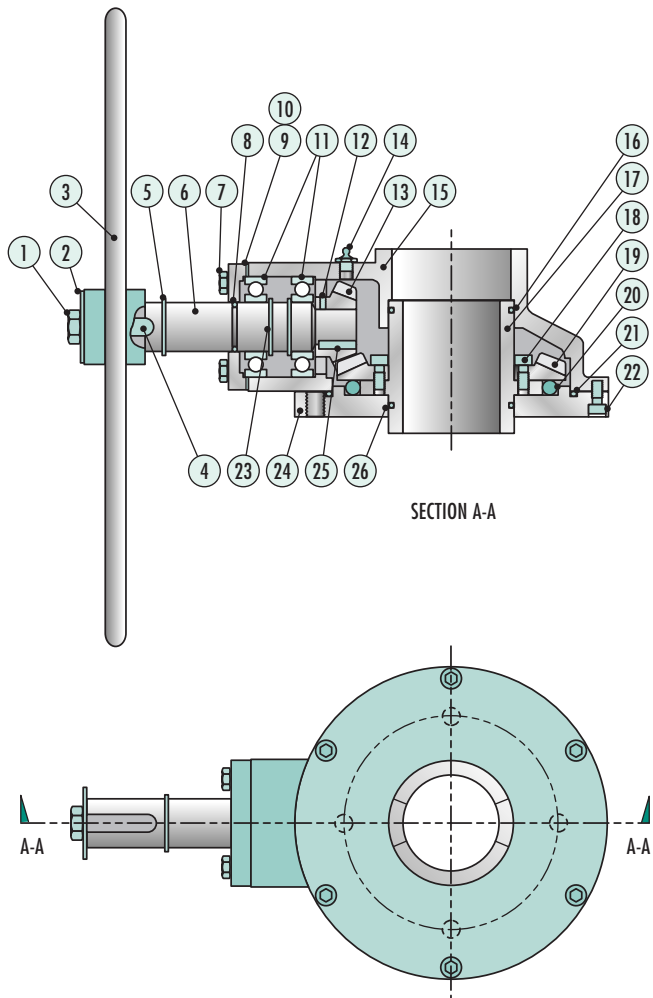

Dimensional Data (in.)

Model	Wt. (lb.)*	A	B	C	D (NPT)	E	F	G	H	I	J	K
BG107	42	8.90	10.80	18.00	3.00	4.76	0.51	2.76	3.50	1.38	2.25	4.08

*Approximate weight without handwheel.

Zy-Gear BG207 Bevel Gear Operator

Parts And Materials

Item	Part Name	Material
1	Hex Bolt	Carbon Steel
2	Washer	Carbon Steel
3	Handwheel	Carbon Steel
4	Key	Carbon Steel
5	Snap Ring	Spring Steel
6	Input Shaft	AISI 1045
7	Hex Nut	Carbon Steel
8	O-Ring	Nitrile
9	Cap	Carbon Steel
10	Gasket	Rubber
12	Ball Bearing	Commercial
13	Pinion	AISI 4135
14	Grease Fitting	Brass
15	Housing	Cast Iron
16	O-Ring	Nitrile
17	Drive Sleeve	Ductile Iron
18	Cap Screw	Carbon Steel
19	Bevel Gear	AISI 4135
20	Balls	Hardened Steel
21	O-Ring	Nitrile
22	Cap Screw	Carbon Steel
23	Snap Ring	Spring Steel
24	Base	Carbon Steel
25	Key	Carbon Steel
26	O-Ring	Nitrile
27	Snap Ring	Steel

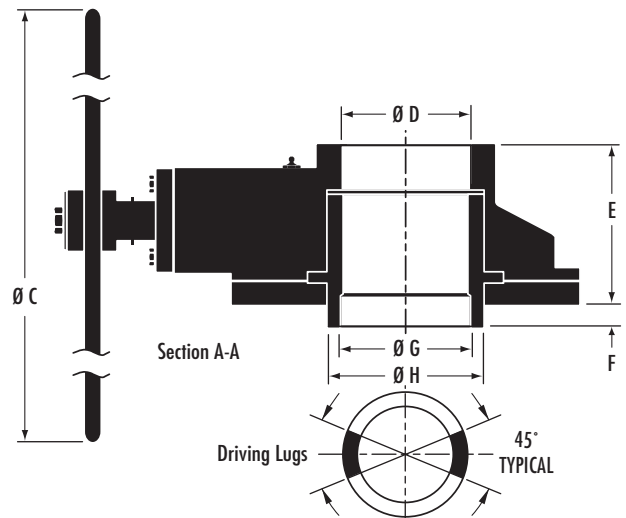
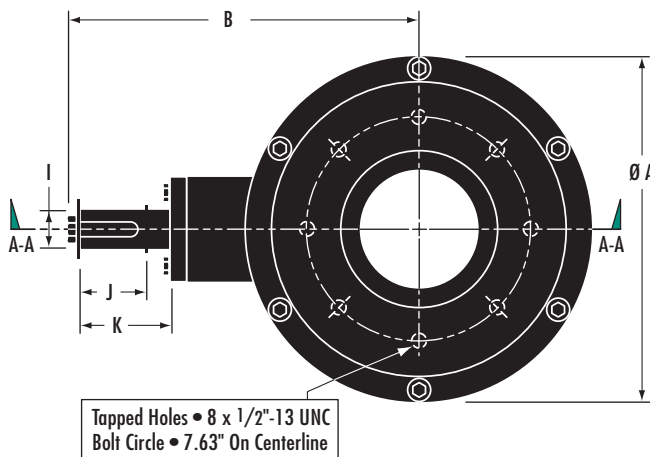
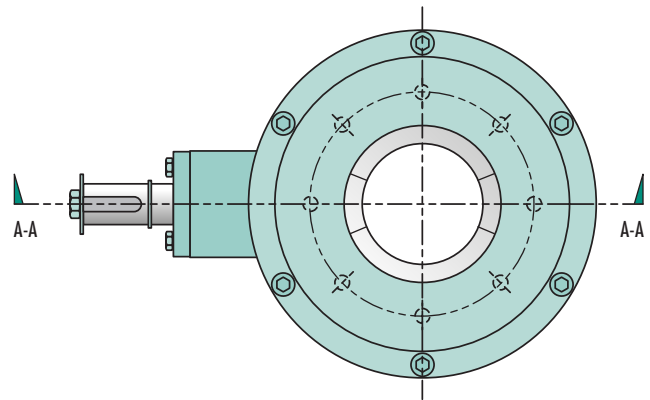
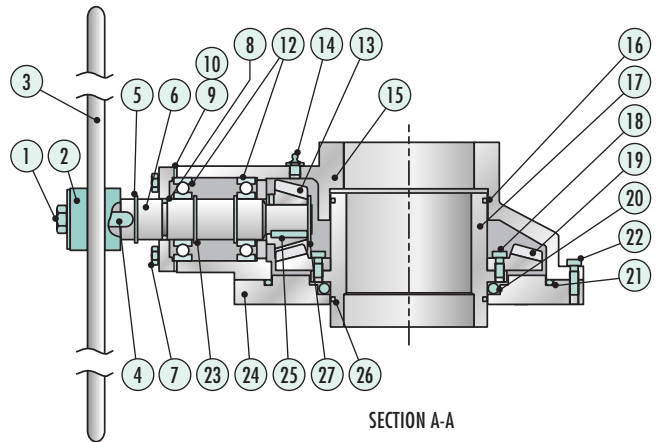

Dimensional Data (in.)

Model	Wt. (lb.)*	A	B	C	D (NPT)	E	F	G	H	I	J	K
BG207	75	11.92	10.79	24.00	4.00	5.47	0.77	4.35	5.24	1.38	2.25	3.04

*Approximate weight without handwheel.

Zy-Gear BG307 Bevel Gear Operator

Parts And Materials

Item	Part Name	Material
1	Hex Bolt	Carbon Steel
2	Washer	Carbon Steel
3	Handwheel	Carbon Steel
4	Key	Carbon Steel
5	Snap Ring	Spring Steel
6	Input Shaft	AISI 1045
7	Hex Nut	Carbon Steel
8	O-Ring	Nitrile
9	Cap	Carbon Steel
10	Gasket	Rubber
11	Ball Bearing	Commercial
13	Pinion	AISI 4135
14	Grease Fitting	Brass
15	Housing	Cast Iron
16	O-Ring	Nitrile
17	Drive Sleeve	Ductile Iron
18	Cap Screw	Carbon Steel
19	Bevel Gear	AISI 4135
20	Balls	Hardened Steel
21	O-Ring	Nitrile
22	Cap Screw	Carbon Steel
23	Snap Ring	Spring Steel
24	Base	Carbon Steel
25	Key	Carbon Steel
26	O-Ring	Nitrile
27	Snap Ring	Steel
28	Cap Screw	Carbon Steel

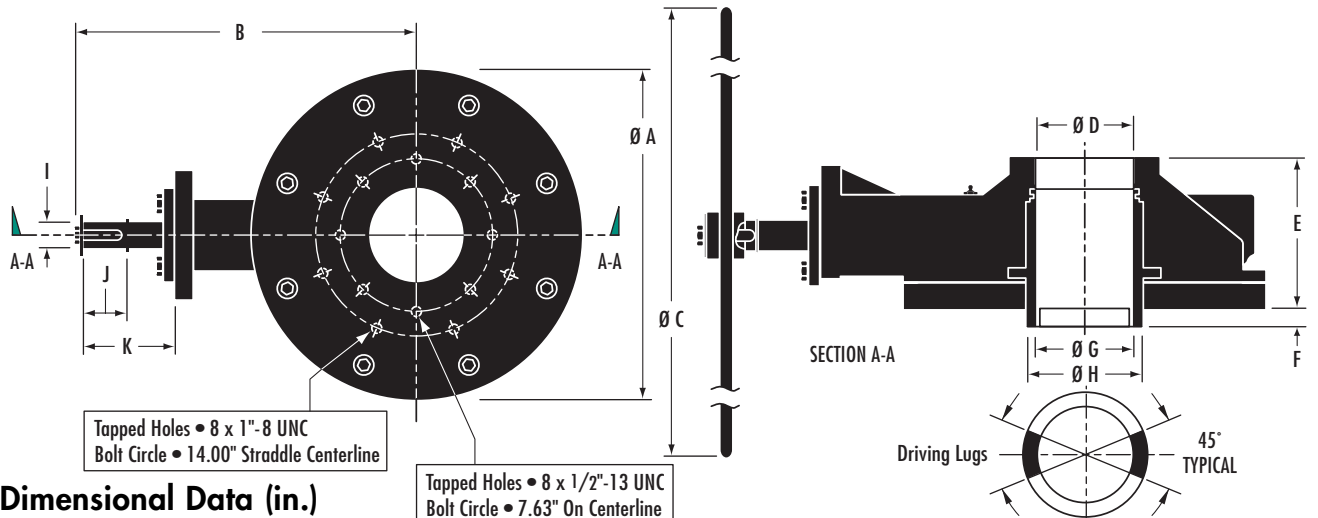
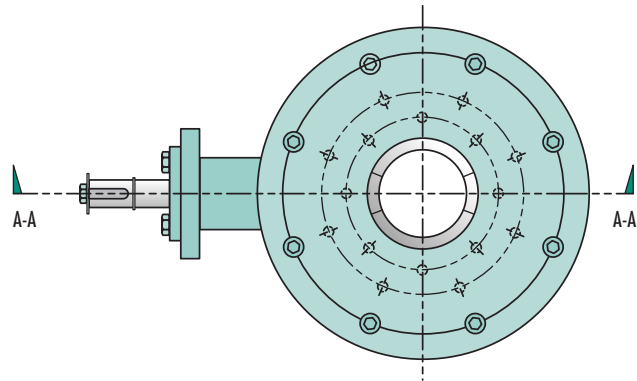
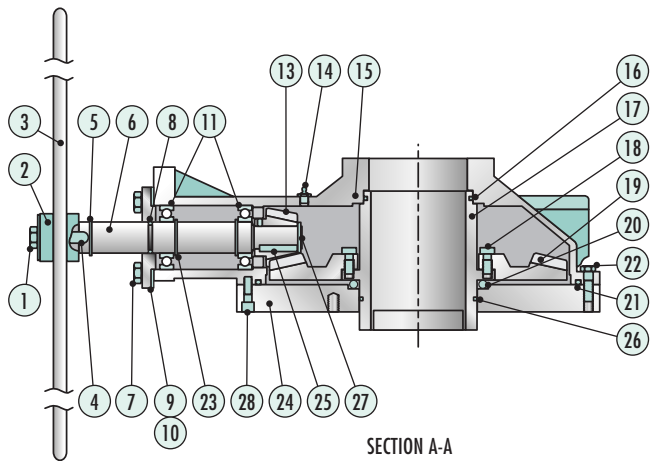

Dimensional Data (in.)

Model	Wt. (lb.)*	A	B	C	D (NPT)	E	F	G	H	I	J	K
BG307	174	16.35	10.79	24.00	4.00	6.91	0.87	4.33	5.38	1.38	2.25	4.66

*Approximate weight without handwheel.